

P1TR MX

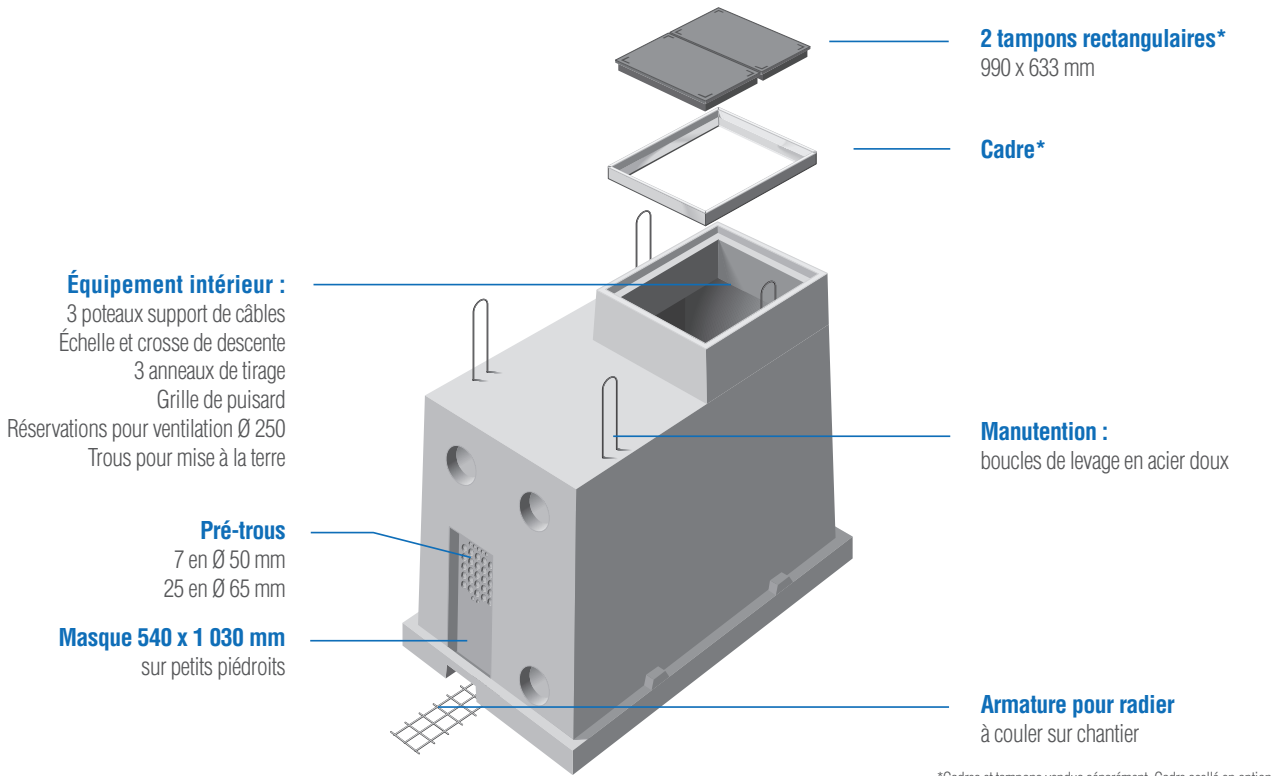

C 250

À RADIER À RECONSTITUER



*Cadres et tampons vendus séparément. Cadre scellé en option.

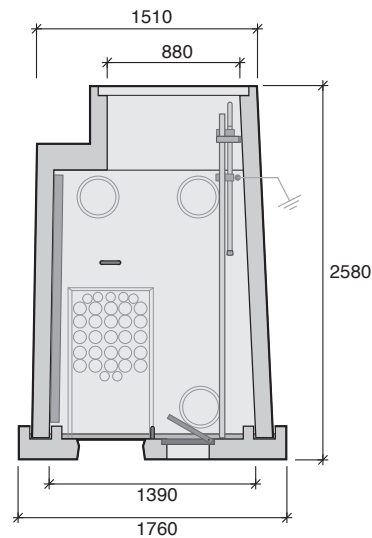
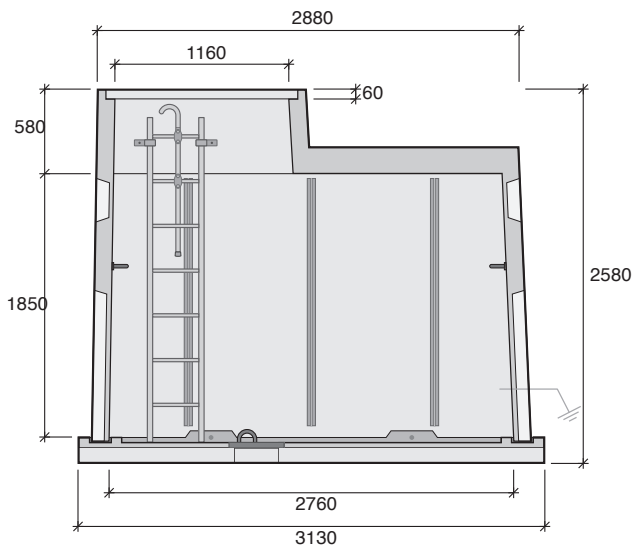

Type L

- L0T
- L0TR
- L1T
- L1TR
- L2T
- L2TR
- L3T
- L3TR
- 1/2L4T
- 1/2L4TR
- L4T
- L4TR
- L5T
- L5TR
- L6T
- L6TR

Type M

- M2T
- M2TR

Type P

- P1T
- P1TR**
- P2T
- P2TR

Désignation	Code	Éléments	Usines	Poids (kg)	Manutention
P1TR	16183010	livré monobloc	MX	8120	4 boucles de levage