

# L5C

## AVEC FOND



D 400

CHAMBRES  
SOUS CHAUSSÉE  
TÉLÉCOMMUNICATIONS

### Type L

- L1C
- L1CR
- L2C
- L2CR
- L3C
- L3CR

**S L5C**

### Type J

- J2C

### Type K

- K1C
- K1CR
- K2C
- K2CR
- K3C
- K3CR

### Type M

- M1C
- M1CR
- M3C
- M3CR

### Type P

- P1C
- P1CR
- P2C
- P2CR

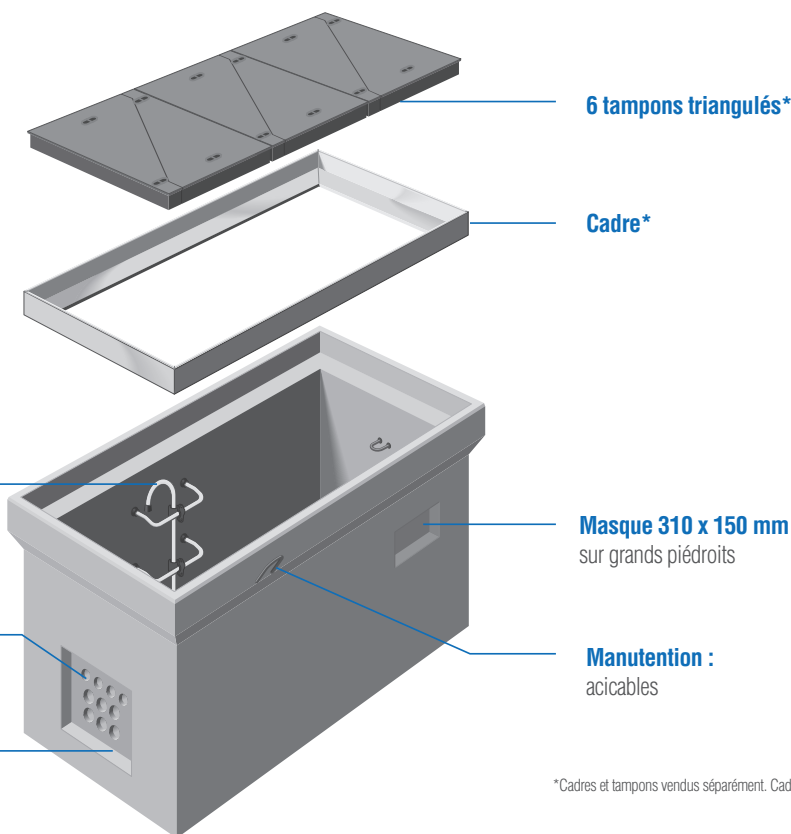

\*Cadres et tampons vendus séparément. Cadre scellé en option.

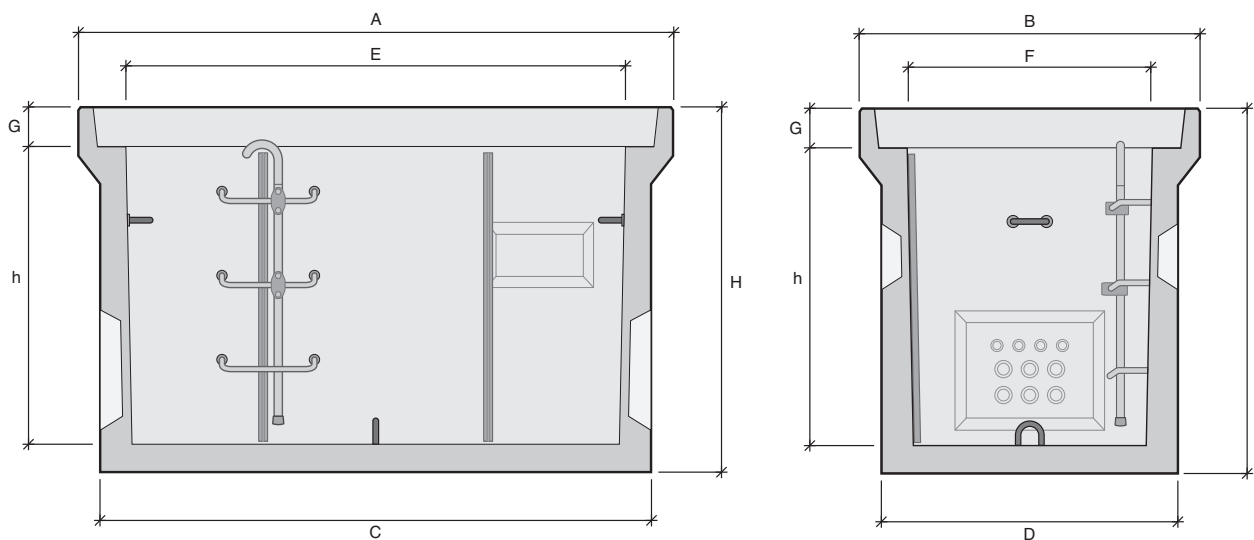

Désignation	Code	Usines	A Longueur (mm)	B Largeur (mm)	C Longueur radier (mm)	D Largeur radier (mm)	E Longueur intérieure (mm)	F Largeur inférieure (mm)	H Hauteur totale (mm)	h Hauteur utile (mm)	G Hauteur feuillure (mm)	Poids (kg)	Manutention
<b>L5C</b>	<b>L5CF1</b>	<b>BI</b>	2130	1220	1970	1060	1790	880	1300	1060	140	2190	2 acicables